

S110

Product Specification

Application

The S110 is a single-jet inferential water meter that operates on the velocity principal, where a jet of water enters the measuring chamber and in turn drives a rotor. The velocity of the rotor is proportional to the flow and the only component that is exposed to the water is the rotor. Water movement is transmitted directly by a magnetic coupling to a dry dial register.

The S110 is suitable for warm water services with temperatures up to 90°C and a maximum working pressure of 1600 kPa.

Counter registration is in cubic metres (m³) and litres.

Each S110 meter is tested for accuracy before delivery and supplied as standard with a set of male screwed BSP brass connections. An integral non-return valve is provided in the outlet end of the meter.

This meter is WaterMark and NMI approved



KEY FEATURES

- Single-jet PICOFLUX EP dry dial meter
- Integrated potential-free pulse output
- Warm water up to 90° C
- Permanent / Continuous flow rate of Q₃ = 1.6 m³/h
- Meter lengths = 115 and 130 mm
- **WaterMark Approved**
GW-WM-0402430-I01-R02
- **NMI Approved** (NMI-14/3/48)
- EU-type examination certification:
DE-11-MIO01-PTB009

S110 PERFORMANCE

NOMINAL METER SIZE (DN mm)		DN15
METER THREAD SIZE	inches	G 3/4" B
PERMANENT / CONTINUOUS FLOW RATE Q ₃	m ³ /h	1.6
STARTING FLOW (APPROXIMATE)	l/h	8.0
OVERLOAD FLOW RATE Q ₄	m ³ /h	2.0
TRANSITIONAL FLOW RATE Q ₂	l/h	64
MINIMUM FLOW RATE Q ₁	l/h	40
FLOW CAPACITY AT 1 BAR PRESSURE LOSS	m ³ /h	2.5
MEASURING RANGE (MID) Q ₃ /Q ₁	H/V	R40
ACCURACY CLASS WARM WATER		Class 2 ± 3% / ± 5% (Low Flow)
MAXIMUM ADMISSIBLE TEMPERATURE	° C	Cold Water = 30° / Warm Water = 90°
MAXIMUM ADMISSIBLE PRESSURE	KPa	1600
MECHANICAL CLASS		M1
PROTECTION CLASS	IP	54
MAGNETIC PROTECTION		EN 14154-3
MIN. STRAIGHT LENGTH OF INLET/OUTLET PIPE		Upstream = 0 / Downstream = 0
NMI PATTERN APPROVAL	Number:	14/3/48
WATERMARK APPROVAL	Number:	GW-WM-0402430-I01-R02

S110

Product Specification

DIMENSIONS

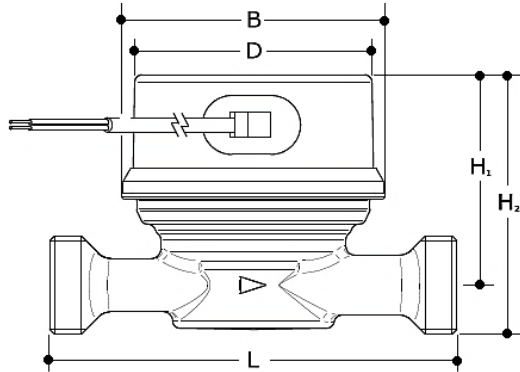

REGISTER

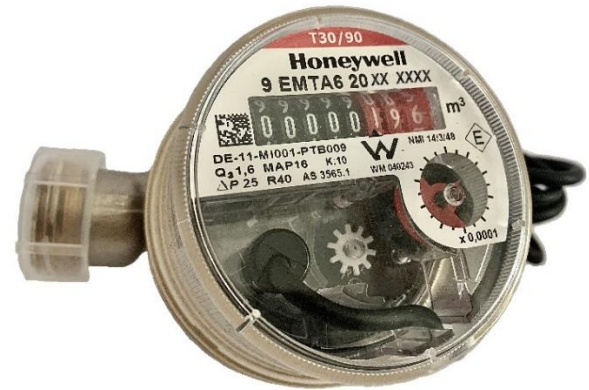

NOMINAL METER SIZE (DN mm)	UNITS	DN15
PERMANENT / CONTINUOUS FLOW RATE Q ₃	m ³ /h	1.6
METER THREAD SIZE	inches	G 3/4" B
OVERALL METER LENGTH (L)	mm	115
OVERALL HEIGHT (H ₂)	mm	71
CENTRELINE HEIGHT (H ₁)	mm	57.5
MAXIMUM DIAMETER (B)	mm	71
DIAMETER AT REGISTER SHROUD (D)	mm	64
BARE WEIGHT - METER ONLY (APPROXIMATE)	kg	0.3

INTEGRATED PULSE OUTPUTS	
PULSE VALUE	10 litres/pulse
SENSOR	Reed switch, potential-free, closing contacts
CONNECTION	Fixed wire, 1.5m length, exit from side of register
CONTACT LOAD	Max. 30 V DC, 50 mA, max. 5 W

For more information

www.elstermetering.com

Elster Metering Pty Ltd

Head Office

55 Northcorp Boulevard
Broadmeadows
Victoria 3047
Australia
T: +61 3 9355 2000
E: ElsterVICSales@Honeywell.com

Elster Metering Pty Ltd

(Honeywell)

19 Corporate Drive
Cannon Hill
Queensland 4170
Australia
T: +61 7 3266 7733
E: ElsterQLDSales@Honeywell.com

Elster Metering Pty Ltd

(Honeywell)

Level 3, 2 Richardson Place
North Ryde
New South Wales 2113
Australia
T: +61 2 8536 7400
E: ElsterNSWSales@Honeywell.com

All rights reserved. The company's policy is one of continuous product improvement and the right is reserved to modify the specifications contained herein without notice. These products have been manufactured with current technology and in accordance with the applicable referenced standards.

Lit Ref: SMLH030 09/19
© 2020 Honeywell International Inc.

Honeywell